

RevNo	Revision note	Date	Signature	Checked
A	NEW RELEASE	05-07-12		

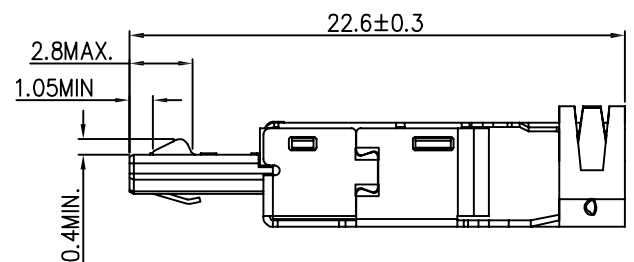
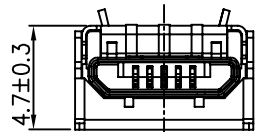
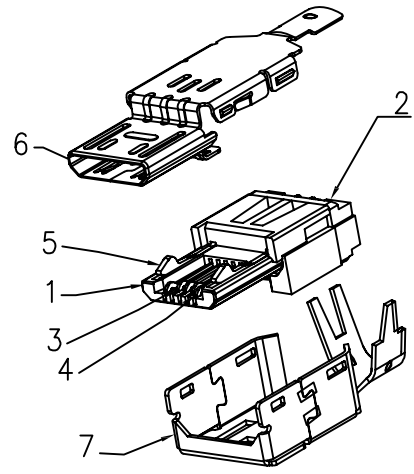
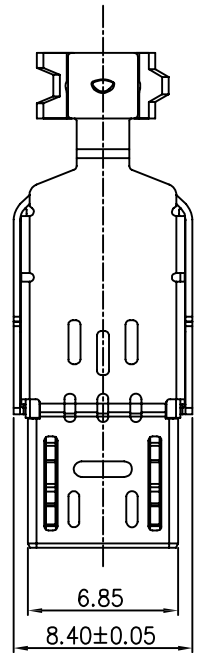

NOTES:

1.MATERIALS :

TOP SHELL : SUS304-3/4H, T=0.20mm
 BOTTOM SHELL : SPCC(D), T=0.30mm
 HOUSING :PA66., UL94V-0
 COVER: PA66, UL94V-0
 CONTACT : BRONZE, C5191R-H, T=0.20mm
 LATCH : SUS304-3/4H, T=0.4mm

2.ELECTRICAL :

INSULATION RESISTANCE : 100 Mohm MIN.
 CONTACT RESISTANCE : 30 mohm MAX.
 DIELECTRIC WITHSTANDING VOLTAGE: 100V AC FOR 1 MINUTE

3.MECHANICAL :

INSERTION FORCE : 35N MAXIMUM
 EXTRACTION FORCE : 8N MIN

PART NO. CODE:

MCB004 - 5 K X - X X
 ① ② ③ ④ ⑤ ⑥

- ① SERIES:
MCB004: MICRO USB PLUG, SOLDER (B TYPE)
- ② POSITIONS:
5: 5 POSITIONS
- ③ INSULATOR COLOR:
B: BLUE
K: BLACK
W: WHITE
C: CREAM
- ④ CONTACT PLATING:
1: Au 1u"
2: Au 3~5u"
4: Au 15u"
5: Au 30u"
- ⑤ ENVIRONMENT:
O: RoHS
H: HALOGEN FREE
- ⑥ WAY OF PACKING:
T: TRAY
R: TAPE & REEL
B: WATERPROOF BAG

BILL OF MATERIAL :

ITEM	PART NAME	Q'TY/EA	MATERIAL	FINISH
7	BOTTOM SHELL	1	SPCC(D)	PLATING TIN
6	TOP SHELL	1	STAINLESS STEEL	PLATING NICKEL
5	CLASP	2	STAINLESS STEEL	NO PLATING
4	CONTACT(3Pin)	3	BRONZE	PLATING GOLD
3	CONTACT(2Pin)	2	BRONZE	PLATING GOLD
2	COVER	1	THERMOPLASTIC	N/A
1	HOUSING	1	THERMOPLASTIC	N/A

GENERAL TOLERANCES (UNLESS SPECIFIED) DIMENSION STYLE : MM (INCH)	<table border="1"> <tr> <th></th> <th>MM</th> <th>ANGLE°</th> </tr> <tr> <td>4 PLACES</td> <td>± ---</td> <td>± ---</td> </tr> <tr> <td>3 PLACES</td> <td>± 0.05</td> <td>± ---</td> </tr> <tr> <td>2 PLACES</td> <td>± 0.13</td> <td>± 0.5°</td> </tr> <tr> <td>1 PLACES</td> <td>± 0.25</td> <td>± 1.0°</td> </tr> <tr> <td>0 PLACES</td> <td>± 0.38</td> <td>± 2.0°</td> </tr> </table>			MM	ANGLE°	4 PLACES	± ---	± ---	3 PLACES	± 0.05	± ---	2 PLACES	± 0.13	± 0.5°	1 PLACES	± 0.25	± 1.0°	0 PLACES	± 0.38	± 2.0°	FINISH SEE NOTES	
		MM	ANGLE°																			
4 PLACES	± ---	± ---																				
3 PLACES	± 0.05	± ---																				
2 PLACES	± 0.13	± 0.5°																				
1 PLACES	± 0.25	± 1.0°																				
0 PLACES	± 0.38	± 2.0°																				
<table border="1"> <tr> <td>DRAWN BY</td> <td>DATE</td> </tr> <tr> <td>R. Ly</td> <td>05-07-12</td> </tr> <tr> <td>CHECKED BY</td> <td>DATE</td> </tr> <tr> <td>A. TENG</td> <td>05-07-12</td> </tr> <tr> <td>APPROVED BY</td> <td>DATE</td> </tr> <tr> <td>---</td> <td>---</td> </tr> </table>	DRAWN BY	DATE	R. Ly	05-07-12	CHECKED BY	DATE	A. TENG	05-07-12	APPROVED BY	DATE	---	---	MATERIAL SEE NOTES	TITLE MICRO USB 5P, SERIES B, MALE, SOLDER TYPE, CABLE								
DRAWN BY	DATE																					
R. Ly	05-07-12																					
CHECKED BY	DATE																					
A. TENG	05-07-12																					
APPROVED BY	DATE																					
---	---																					
THIRD ANGLE PROJECTION		SIZE A4	DRAWING NO. MCB004-5KX-XX	SCALE NONE	SHEET 1 OF 1	REV. A																