

| RevNo | Revision note | Date | Signature | Checked |
|-------|--|----------|-----------|---------|
| A | NEW RELEASE | 02-28-12 | | |
| B | UPDATED THE DESCRIPTION OF THE TITLE BLOCK | 04-23-12 | | |

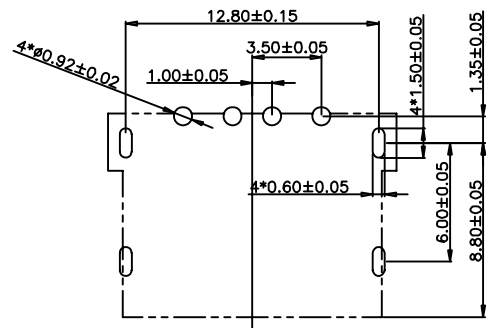

RECOMMENDED P.C.B.LAYOUT
(PCB T=1.60 MAX.)

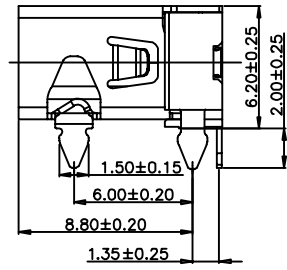
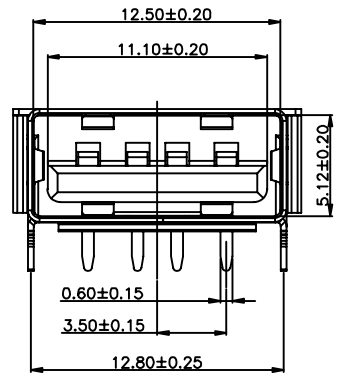
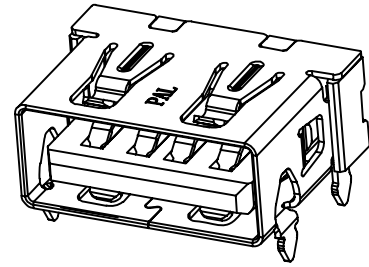
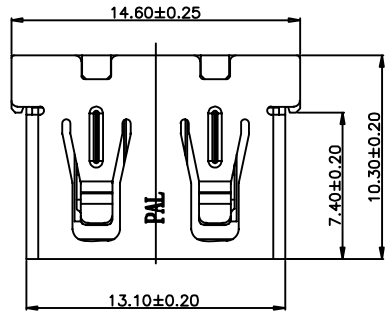
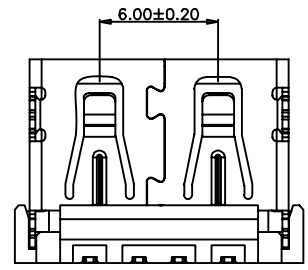

- NOTES:
- HOUSING MATERIAL: PBT + 30%GF
 - CONTACT MATERIAL: PHR BRONZE C5191R-H,
T=0.25±0.01mm
 - OUTER SHELL MATERIAL: BRASS C2680R-H,
T=0.30±0.01mm
 - CONTACT PLATING:
NICKEL UNDERPLATING OVER ALL
GOLD PLATING AT CONTACT AREA
TIN PLATING AT SOLDERING AREA
 - SHELL PLATING: NICKEL
 - ELECTRICAL PERFORMANCES:
CURRENT RATING: 1.5A AT 250 VAC MIN.
LOW LEVEL CONTACT RESISTANCE: 30 mΩ MAX.
INSULATION RESISTANCE: 1000 MΩ MIN.
DIELECTRIC WITHSTANDING VOLTAGE: 500V AC FOR
1 MINUTE

PART NO. CODE:
U2A136 - 4 X X - X X
① ② ③ ④ ⑤ ⑥

- SERIES:
U2A136: USB 2.0 CONN, SERIES A, SINGLE DECK,
R/A, THROUGH HOLE TYPE, L=10.3
- POSITIONS:
4: 4 POSITIONS
- INSULATOR COLOR:
K: BLACK
W: WHITE
- CONTACT PLATING:
1: Au 1u"
2: Au 3~5u"
3: Au 10u"
4: Au 15u"
5: Au 30u"
- ENVIRONMENT:
O: RoHS
H: HALOGEN FREE
- WAY OF PACKING:
T: TRAY
R: TAPE & REEL
B: WATERPROOF BAG

BILL OF MATERIAL :

| ITEM | PART NAME | Q'TY/EA | MATERIAL | PLATING |
|------|-----------|---------|------------|------------|
| 3 | SHELL | 1 | BRASS | NICKEL |
| 2 | CONTACT | 4 | PHR BRONZE | AU OVER Ni |
| 1 | HOUSING | 1 | PBT+30%GF | N/A |

GENERAL TOLERANCES
(UNLESS SPECIFIED)
DIMENSION STYLE : MM < INCH >

| | MM | ANGLE° |
|----------|--------|--------|
| 4 PLACES | ± --- | ± --- |
| 3 PLACES | ± 0.05 | ± --- |
| 2 PLACES | ± 0.13 | ± 0.5° |
| 1 PLACES | ± 0.25 | ± 1.0° |
| 0 PLACES | ± 0.38 | ± 2.0° |

THIRD ANGLE PROJECTION

| FINISH | |
|-------------|----------|
| SEE NOTES | |
| MATERIAL | |
| SEE NOTES | |
| DRAWN BY | DATE |
| R. Ly | 04-23-12 |
| CHECKED BY | DATE |
| A. TENG | 04-23-12 |
| APPROVED BY | DATE |
| --- | --- |

PALCONN

TITLE: USB 2.0, 4P, SERIES A, FEMALE, R/A, 4 MTN. POSTS, THROUGH HOLE TYPE

SIZE: A4 DRAWING NO. U2A136-4XX-XX

SCALE: NONE SHEET 1 OF 1 REV. B