

ABIDE BY ROHS,MEETS PT ENVIRONMENTAL Q3-7584

REV.	DESCRIPTION	ECN NO.	NEW DESIGNER
A	NEW RELEASE		LZW 2015.12.21
B	Increase size		LZW 2016.1.5

NOTES:

- MATERIALS:
SHELL: STAINLESS STEEL;
MIDDLE CONTACT: STAINLESS STEEL;
HOUSING: THERMOPLASTIC, UL94-V0, BLACK;
CONTACT: HIGH-CONDUCTIVITY COPPER ALLOYS;
- PLATING:
CONTACT: 80u"Min. NICKEL UNDERPLATING OVERALL;
PLATED GOLD 30u"Min. ON CONTACT AREA,
OR REFERENCE PART NO. CODE;
PLATED Au 1u"Min. ON SOLDER AREA;
SHELL: PLATED NICKEL;
- DIMENSIONAL TOLERANCE:
NOT SPECIFIED TOLERANCE, COMPLIED TO THE GENERAL TOLERANCE;
CONTROL DIMENSIONS INDICATED FORM "▼", MUST BE INSPECTED BY QC;
- ELECTRICAL CHARACTERISTICS:
LOW LEVEL CONTACT RESISTANCE: 40mΩ Max;
INSULATION RESISTANCE: 100MΩ Min.;
DIELECTRIC WITHSTANDING VOLTAGE: 100 VAC;
CONTACT CURRENT RATING: 5A Max;
- MECHANICAL CHARACTERISTICS:
INSERTION FORCE: 5~20N;
EXTRACTION FORCE: 8~20N;
DURABILITY: 10000 CYCLES;
- IR REFLOW CONDITION PEAK TEMPERATURE: 260°C~10S

PART NO. CODE:

UTC016 - G K * - H R
① ② ③ ④ ⑤ ⑥

- ① SERIES:
UTC016: USB 2.0 TYPE C RECEPTACLE,
RIGHT ANGLE SMT TYPE

- ② POSITIONS:
C: 16 POSITIONS
O: RoHS
H: HALOGEN FREE
- ③ COLOR OF HOUSING:
K: BLACK
W: WHITE
- ④ CONTACT PLATED:
2: PLATED Au 3u" MIN
3: PLATED Au 10u" MIN
5: PLATED Au 30u" MIN
- ⑤ ENVIRONMENT:
O: RoHS
H: HALOGEN FREE
- ⑥ WAY OF PACKING:
R: TAPE & REEL

USB TYPE-C 2.0 INTERFACE PIN DEFINITION			
PIN	Signal Name	PIN	Signal Name
A1	GND	B12	GND
A4	VBUS	B9	VBUS
A5	CC1	B8	SBU2
A6	D+	B7	D-
A7	D-	B6	D+
A8	SBU1	B5	CC2
A9	VBUS	B4	VBUS
A12	GND	B1	GND

Patent pending

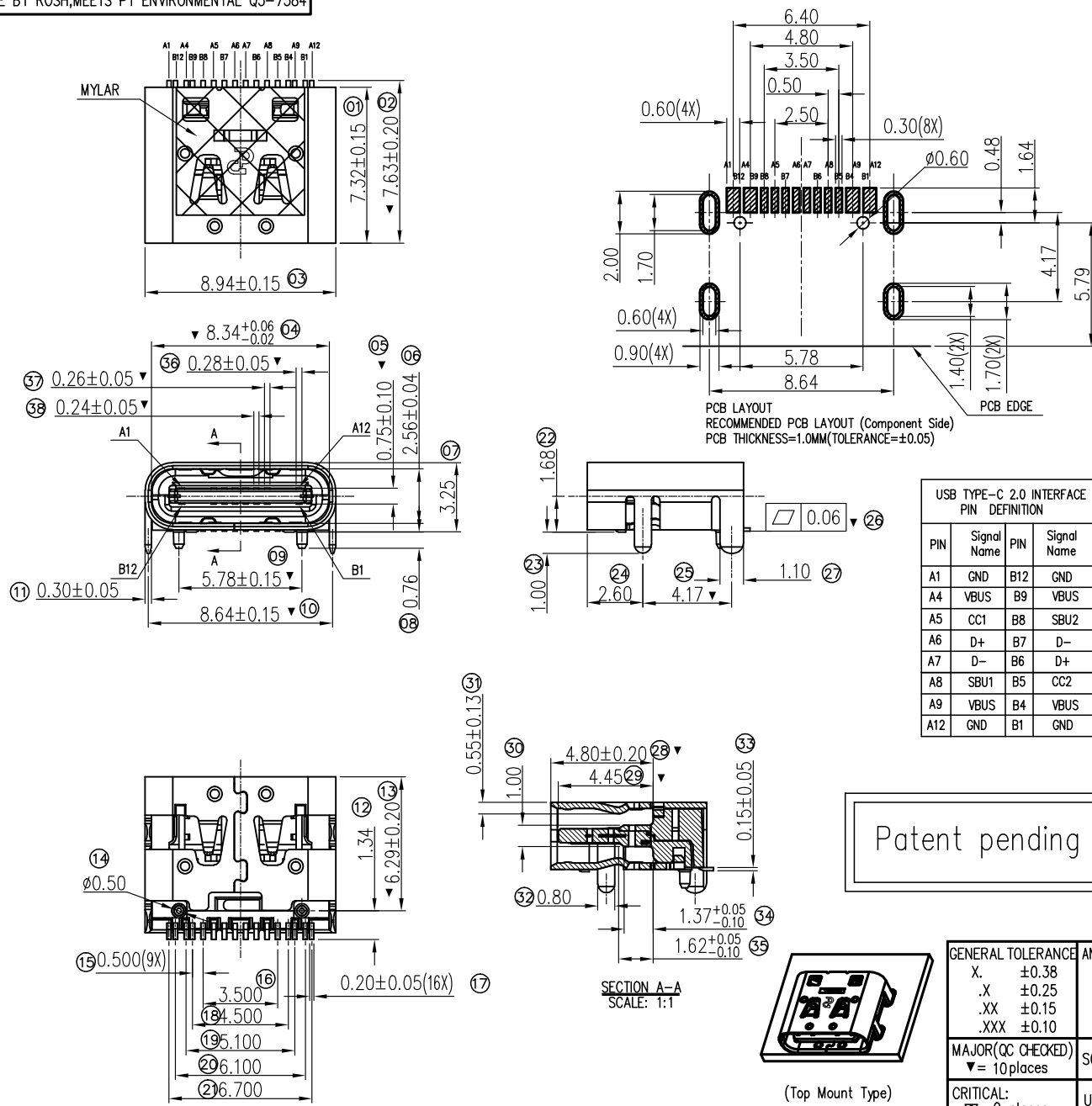

GENERAL TOLERANCE		ANGLE TOLERANCE		NAME (INTENDED USE):	
X.	±0.38	X.*	±3.0°	CUSTOMER DRAWING	
.X	±0.25	.X*	±2.0°	PART NO. CODE:	
.XX	±0.15	.XX*	±1.0°	UTC016-G**-**	
.XXX	±0.10			TITLE:	
MAJOR (QC CHECKED) ▼ = 10 places				SCALE: 1:1	APPROVED:
CRITICAL: ▽ = 0 places				UNIT: mm	CHECKED:
SHEET 1 OF 1				DESIGN:	
				DRAWING NO.:	C-UTC016-02
				SERIES:	USB TYPE C
				SIZE:	A4
				REV.:	B



PALCONN TECHNOLOGY CO., LTD.
TITLE:
USB 2.0 TYPE C RECEPTACLE,
RIGHT ANGLE SMT TYPE

ABIDE BY ROHS,MEETS PT ENVIRONMENTAL Q3-7584

REV.	DESCRIPTION	ECN NO.	NEW DESIGNER
A	NEW RELEASE		LZW 2015.12.16
B	Increase size		LZW 2016.1.5

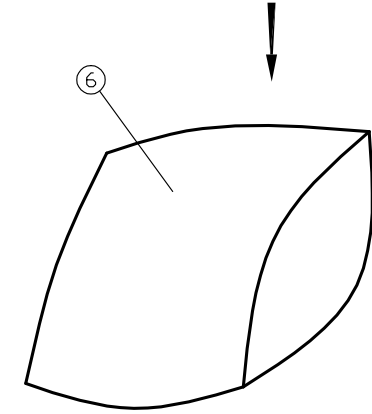
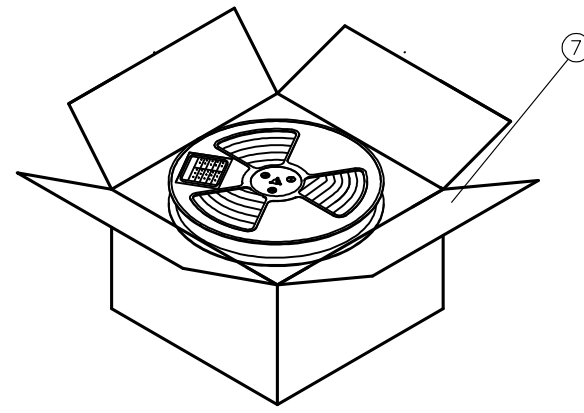
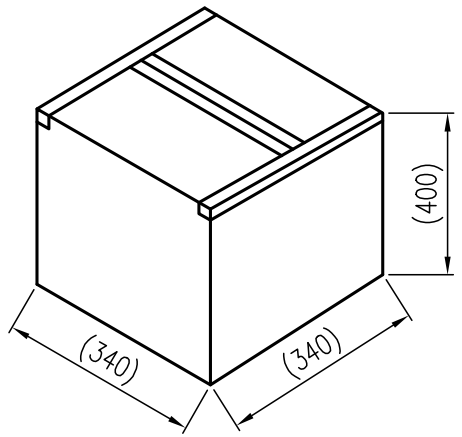
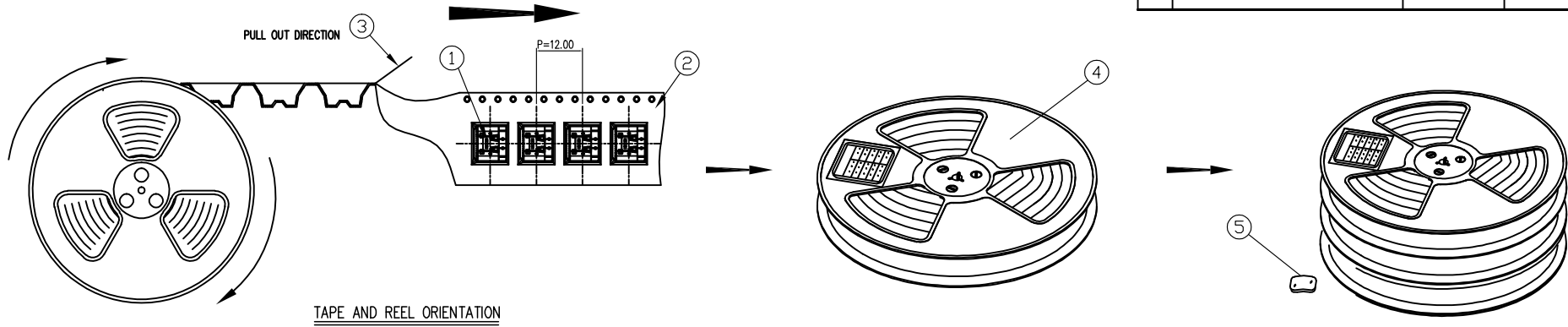

BILL OF MATERIAL:

ITEM	PART NAME	QTY	MATERIAL
7	TRIANGLE CARDBOARD	1	K=K
6	ANTI-WATER POLYBAG	1	PE
5	DESICCANT	5	/
4	REEL	10	PS(BLUE)
3	COVER TAPE	11.28X10M	PET T=0.07mm
2	CARRIER TAPE	11.28X10M	PS T=0.40mm
1	PRODUCT	9000PCS	0.43g/pcs

LEADER AND TRAILER TAPE

- COVER TAPE PEELING FORCE IN THE DIRECTION SHOWN SHALL BE 0.20N MIN.
- TAPE AND REEL MATERIALS:
 - CARRIER TAPE: POLYPROPYLENE OR POLYSTYRENE- ANTI-ESD
 - COVER TAPE: TREATED FOR ANTI-ESD
 - REEL: POLYPROPYLENE OR POLYSTYRENE
- PACKING QUANTITY AND STYLE:
 - QUANTITY: 900 PCS/REEL
 - 10 REELS / OUTER CARTON
 - 9000 PCS/ OUTER CARTON
- PACKING STYLE: TAPE&REEL
- PRODUCT THE WEIGHT OF THE: 0.43g

GENERAL TOLERANCE	ANGLE TOLERANCE	NAME (INTENDED USE):	 PALCONN TECHNOLOGY CO.,LTD.
X. ±0.38 .X ±0.25 .XX ±0.20 .XXX ±0.15	X.* ±3.0° .X.* ±2.0° .XX.* ±1.0°	CUSTOMER DRAWING	
MAJOR (QC CHECKED) ▽= 0 places	SCALE: 1:1	APPROVED:	TITLE: USB 2.0 TYPE C RECEPTACLE, RIGHT ANGLE SMT TYPE
CRITICAL: ▽= 0 places	UNIT: mm	CHECKED:	SERIES: USB TYPE C
SHEET 1 OF 1	DESIGN:		SIZE: A4
			DRAWING NO.: C-UTC016-02
			REV.: B