

RevNo	Revision note	Date	Signature	Checked
B	REVISED THE TITLE BLOCK	04-24-12		

NOTES:

- MATERIALS:  
 OUTER SHELL: STAINLESS STEEL, T=0.30mm  
 HOUSING: THERMOPLASTIC  
 CONTACT: PHR BRONZE, T=0.20mm  
 BACK COVER: THERMOPLASTIC
- CONTACT PLATING:  
 NICKEL UNDERPLATING OVER ALL  
 GOLD PLATING AT CONTACT AREA  
 GOLD FLASH AT SOLDERING AREA
- SHELL PLATING:  
 PLEASE REFER TO THE PART NO. CODE DEFINED
- ELECTRICAL:  
 INSULATION RESISTANCE: 100 MΩ MIN.  
 CONTACT RESISTANCE: 30 mΩ MAX.  
 DIELECTRIC WITHSTANDING VOLTAGE: 100V  
 CURRENT RATING: 1.5A AT 250 VAC MIN.

PART NO. CODE:

U3A023 - 9 B X - X X  
 ① ②③④ ⑤⑥

- SERIES:  
 U3A023: USB 3.0 CONN, SERIES A,  
 SINGLE DECK, R/A, THRU-HOLE TYPE
- POSITIONS:  
 9: 9 POSITIONS
- INSULATOR COLOR:  
 B: BLUE
- CONTACT PLATING:  
 1: Au 1u"  
 2: Au 3~5u"  
 4: Au 15u"  
 5: Au 30u"
- ENVIRONMENT:  
 O: RoHS  
 H: HALOGEN FREE
- WAY OF PACKING:  
 T: TRAY  
 R: TAPE & REEL  
 B: WATERPROOF BAG

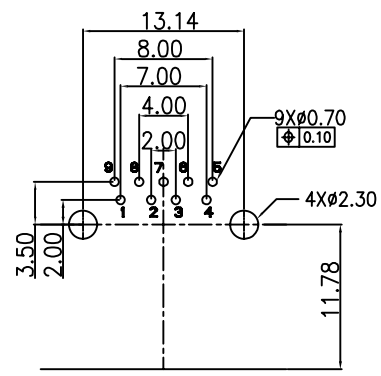
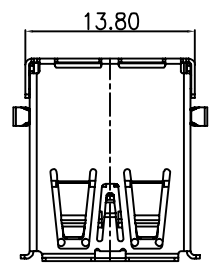

REFERENCE PCB LAYOUT

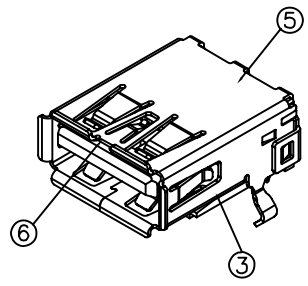
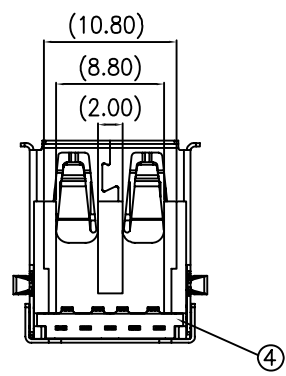
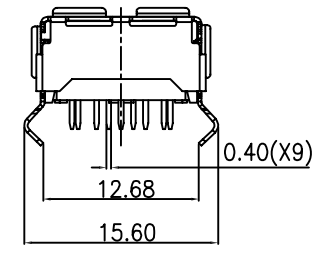
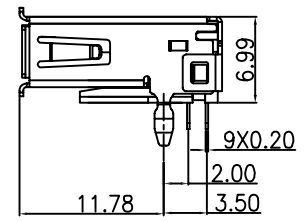
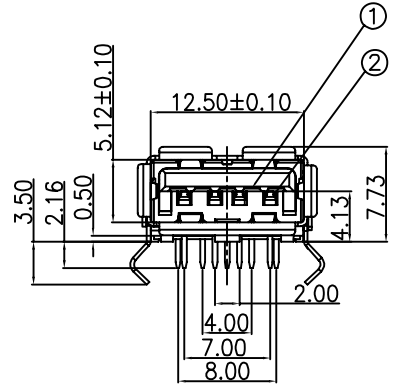

BILL OF MATERIAL :

6	INSULATOR	1	BRASS+THERMOPLASTIC	N/A
5	OUTER SHELL	1	STAINLESS STEEL	NICKEL/CLEAN
4	BACK COVER	1	THERMOPLASTIC	N/A
3	HOUSING	1	THERMOPLASTIC	N/A
2	CONTACT	4	POSPHOR BRONZE	AU OVER NI.
1	CONTACT	5	BRASS	AU OVER NI.
ITEM	PART NAME	Q'TY	MATERIAL	PLATING

GENERAL TOLERANCES ( UNLESS SPECIFIED ) DIMENSION STYLE : MM < INCH >		
	MM	ANGLE°
4 PLACES	± ---	± ---
3 PLACES	± 0.05	± ---
2 PLACES	± 0.13	± 0.5°
1 PLACES	± 0.25	± 1.0°
0 PLACES	± 0.38	± 2.0°
THIRD ANGLE PROJECTION		

FINISH		SEE NOTES
MATERIAL		SEE NOTES
DRAWN BY	DATE	
R. Ly	04-24-12	
CHECKED BY	DATE	
A. TENG	04-24-12	
APPROVED BY	DATE	
---	---	

<b>PALCONN</b>			
TITLE USB 3.0, 9P, SERIES A, FEMALE, R/A, THRU-HOLE TYPE			
SIZE	A4	DRAWING NO.	U3A023-9BX-XX
SCALE	NONE	SHEET	1 OF 1
		REV.	B