

RevNo	Revision note	Date	Signature	Checked
A	NEW RELEASE	01-04-12		
B	UPDATED THE DESCRIPTION OF THE TITLE BLOCK	04-23-12		

NOTES:

- INSULATOR MATERIAL : THERMOPLASTIC
- CONTACT MATERIAL : BRASS/PHOSPHOR BRONZE, T=0.25±0.01mm
- SHELL MATERIAL : BRASS/SPCC, T=0.30±0.01mm
- CONTACT PLATING :
NICKEL UNDERPLATING OVER ALL
GOLD PLATING AT CONTACT AREA
TIN PLATING AT SOLDERING AREA
- SHELL PLATING : NICKEL
- ELECTRICAL PERFORMANCES:
CURRENT RATING: 1.5A AT 250 VAC MIN.
CONTACT RESISTANCE: 30 mΩ MAX;
INSULATION RESISTANCE: 1000 MΩ MIN
DIELECTRIC WITHSTANDING VOLTAGE: 500V
AC FOR 1 MINUTE

PART NUMBERING CODE

U2A017 - 4 * * - * *
① ② ③ ④ ⑤ ⑥

- SERIES :
U2A017 : USB 2.0 CONNECTOR, SERIES A, SINGLE DECK
RIGHT ANGLE THROUGH HOLE TYPE
- POSITIONS:
4 : 4 POSITIONS.
- INSULATOR COLOR
K : BLACK
W : WHITE
- CONTACT PLATING :
1: Au 1u"
2: Au 3~5u"
4: Au 15u"
5: Au 30u"
- ENVIRONMENT:
0 : RoHS
H : HALOGEN FREE
- WAY OF PACKING:
T: TRAY
R: TAPE & REEL
B: WATERPROOF BAG

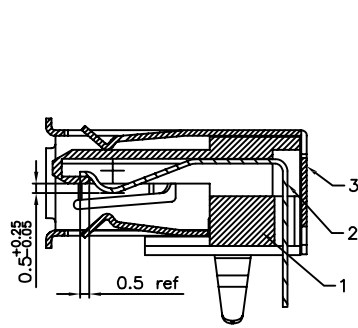

SECTION A-A

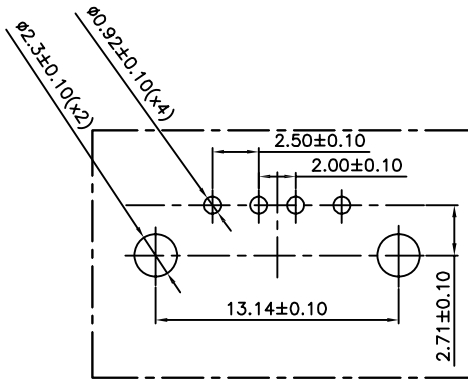
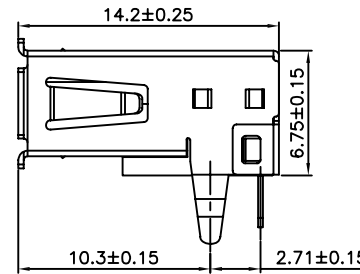
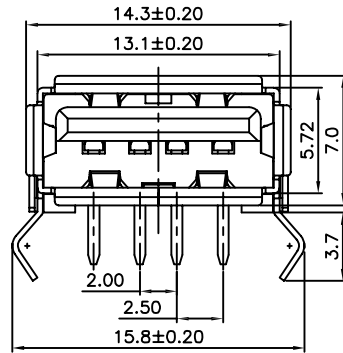
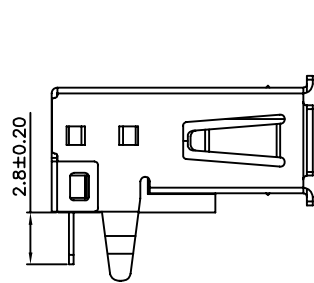
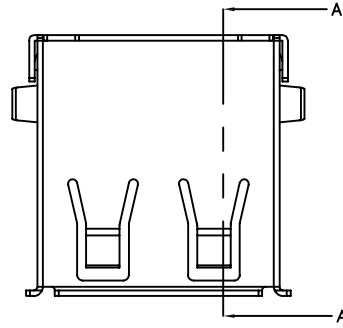

PCB LAYOUT

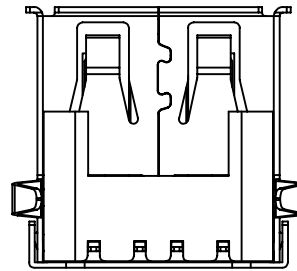

BILL OF MATERIAL :

ITEM	PART NAME	Q'ITY/EA	MATERIAL	PLATING
3	SHELL	1	BRASS/SPCC	PLATING NICKEL
2	CONTACT	4	BRASS/PHOSPHOR BRONZE	AU
1	HOUSING	1	THERMOPLASTIC	N/A

GENERAL TOLERANCES
(UNLESS SPECIFIED)
DIMENSION STYLE : MM (INCH)

	MM	ANGLE°
4 PLACES	± 0.05	± 0.5°
3 PLACES	± 0.13	± 1.0°
2 PLACES	± 0.25	± 2.0°
1 PLACES	± 0.38	
0 PLACES		



FINISH	
SEE NOTES	
MATERIAL	
SEE NOTES	
DRAWN BY	DATE
R. Ly	04-20-12
CHECKED BY	DATE
A. TENG	04-20-12
APPROVED BY	DATE
---	---



TITLE	
USB 2.0, 4P, SERIES A, FEMALE, R/A, THROUGH HOLE TYPE	
SIZE	DRAWING NO.
A4	U2A017-4XX-XX
SCALE	SHEET
NONE	1 OF 1
REV.	
B	