

| RevNo | Revision note | Date | Signature | Checked |
|-------|---------------|----------|-----------|---------|
| A | NEW RELEASE | 05-07-12 | | |

NOTES:

- HOUSING MATERIAL: PBT+30%GF
- LONG CONTACT MATERIAL: BRASS C2680R-EH, T=0.25±0.01mm
- SHORT CONTACT MATERIAL: BRASS C2680R-EH, T=0.25±0.01mm
- BACK SHELL MATERIAL: SPCC, T=0.30±0.01mm
- OUTER SHELL MATERIAL: BRASS, C2680R-H, T=0.30±0.01mm
- INNER SHELL MATERIAL: Mn-STEEL, T=0.30±0.01mm
- CONTACT PLATING:

NICKEL UNDERPLATING OVER ALL
GOLD PLATING AT CONTACT AREA
TIN PLATING AT SOLDERING AREA

- SHELL PLATING: NICKEL

- ELECTRICAL PERFORMANCES:

CURRENT RATING: 1.5A AT 250 VAC MIN.
LOW LEVEL CONTACT RESISTANCE: 30 mΩ MAX.
INSULATION RESISTANCE: 1000 MΩ MIN.
DIELECTRIC WITHSTANDING VOLTAGE: 500V AC
FOR 1 MINUTE

PART NO. CODE:

U2C104 - 8 X X - X X
① ② ③ ④ ⑤ ⑥

- SERIES:

U2C104: USB 2.0 CONN, SERIES A,
DOUBLE DECK, RIGHT ANGLE,
THROUGH HOLE TYPE

- POSITIONS:

8: 8 POSITIONS

- COLOR OF HOUSING:

K: BLACK
W: WHITE

- CONTACT PLATING:

1: Au 1u"
2: Au 3~5u"
3: Au 10u"
4: Au 15u"
5: Au 30u"

- ENVIRONMENT:

O: RoHS
H: HALOGEN FREE

- WAY OF PACKING:

T: TRAY
R: TAPE & REEL
B: WATERPROOF BAG

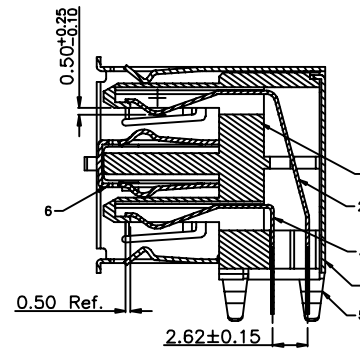
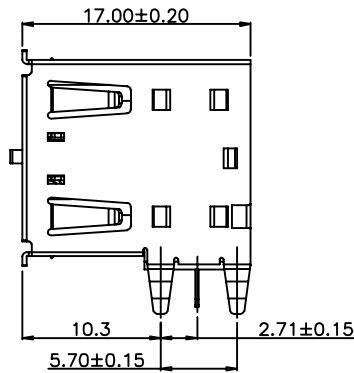
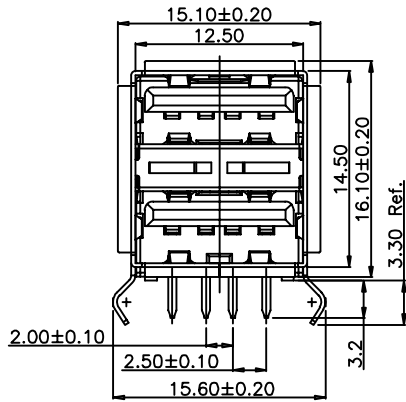
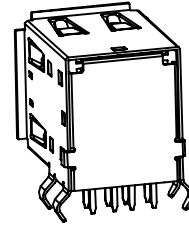
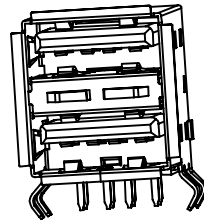
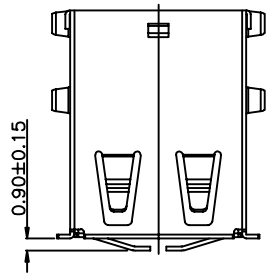

SECTION A-A

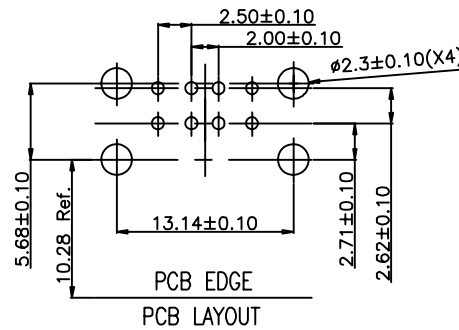
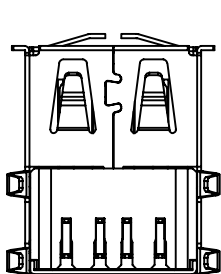

BILL OF MATERIAL :

| ITEM | PART NAME | Q'TY/EA | MATERIAL | PLATING |
|------|---------------|---------|----------|----------------------|
| 6 | INNER SHELL | 1 | Mn-STEEL | NICKEL PLATING / TIN |
| 5 | OUTER SHELL | 1 | BRASS | NICKEL PLATING / TIN |
| 4 | BACK SHELL | 1 | SPCC | NICKEL PLATING / TIN |
| 3 | SHORT CONTACT | 4 | BRASS | AU OVER Ni |
| 2 | LONG CONTACT | 4 | BRASS | AU OVER Ni |
| 1 | HOUSING | 1 | PBT | N/A |

GENERAL TOLERANCES
(UNLESS SPECIFIED)
DIMENSION STYLE : MM (INCH)

| | MM | ANGLE* |
|----------|--------|--------|
| 4 PLACES | ± --- | ± --- |
| 3 PLACES | ± 0.05 | ± --- |
| 2 PLACES | ± 0.13 | ± 0.5° |
| 1 PLACES | ± 0.25 | ± 1.0° |
| 0 PLACES | ± 0.38 | ± 2.0° |



| | |
|-------------|-----------|
| FINISH | SEE NOTES |
| MATERIAL | SEE NOTES |
| DRAWN BY | DATE |
| R. Ly | 05-07-12 |
| CHECKED BY | DATE |
| A. TENG | 05-07-12 |
| APPROVED BY | DATE |
| --- | --- |



TITLE
USB 2.0, 8P, SERIES A, FEMALE,
R/A, DUAL, THROUGH HOLE TYPE

SIZE A4 DRAWING NO. U2C104-8XX-XX

SCALE NONE SHEET 1 OF 1 REV. A